



Harrington's AW Series Certified Spark Resistant Wash Down Air Hoists



MODEL: AW005P

Harrington's AW Series  Certified Spark Resistant Wash Down Air Hoists are designed for use in humid, limited corrosive or outdoor environments and where equipment must be washed or hosed off on a regular basis. These industrial, severe-duty rated hoists are  certified spark resistant (Explosive atmospheres that require features that reduce the risk of spark) to level  II 2GD c T5 IIB T100°C and are in compliance with the EU ATEX Directive. AW Wash Down Air Hoists were built based on our AL Lube Free air hoists and therefore they are suitable for operation with or without lubrication in the air supply.

Sanitary solutions

Dependable features

- Available in ½ and 1 Ton capacities
- Unpainted aluminum body
- Stainless steel and electro-plated external components
- Gear box and chain lubricants comply with FDA standards
- Heavy-duty, self-adjusting, patented disk brake
- Bearing supported planetary gearing system
- Upper and lower limit switches

Applications

- Food processing and food handling facilities
- Pharmaceutical industry
- Hygienic environments
- Humid, limited corrosive and outdoor environments

Available options

- Self-locking hooks
- Adjustable chain stops
- Load limiter
- Twist rod control
- Filter, regulator, lubricator
- Chain container

Ask your local sales representative or call our Customer Service staff for friendly and expert advice on models and options.

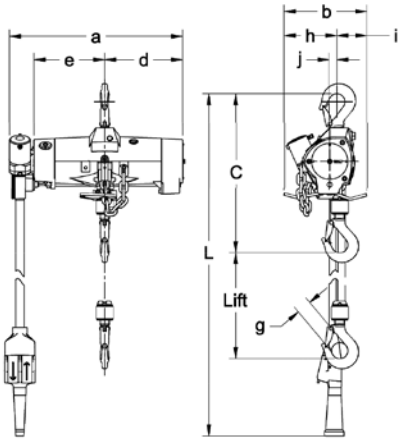

AW005P

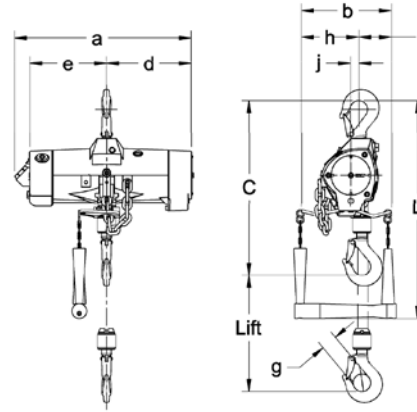

AW005C

AW PENDANT MODEL—SPECIFICATIONS

Cap. (Tons)	Product Code	Standard Lift (ft)	Push Button Hose L (ft)	Up/Down Speeds (ft/min @ 90psi)		Up/Down Air Consumption Rates (cubic ft/min @ 90 psi)		Load Chain Diameter (mm) x Chain Fall Lines	Net Weight (lbs)	Weight for Additional One Foot of Lift (lbs)
				No Load	w/Full Load	No Load	w/Full Load			
1/2	AW005P	10	7.5	78 / 49	41 / 72	102 / 68	81 / 74	6.5x1	39	0.6
1	AW010P2			39 / 25	21 / 36	102 / 68	81 / 74	6.5x2	55	1.2

AW PENDANT MODEL—DIMENSIONS

Capacity (Tons)	Product Code	Headroom C (in)	a (in)	b (in)	d (in)	e (in)	g (in)	h (in)	i (in)	j (in)
1/2	AW005P	14.8	15.9	7.7	7.2	6.6	1.1	5.1	2.6	1.0
1	AW010P2	17.5	15.9	7.7	7.2	6.6	1.1	5.1	2.6	1.0

AW CORD MODEL—SPECIFICATIONS

Cap. (Tons)	Product Code	Standard Lift (ft)	Cord L (ft)	Up/Down Speeds (ft/min @ 90psi)		Up/Down Air Consumption Rates (cubic ft/min @ 90 psi)		Load Chain Diameter (mm) x Chain Fall Lines	Net Weight (lbs)	Weight for Additional One Foot of Lift (lbs)
				No Load	w/Full Load	No Load	w/Full Load			
1/2	AW005C	10	7.5	78 / 49	41 / 72	102 / 68	81 / 74	6.5x1	37.5	0.6
1	AW010C2			39 / 25	21 / 36	102 / 68	81 / 74	6.5x2	53	1.2

For optional Twist Rod Control – Rod L = 3.5 to 6.5 feet.

AW CORD MODEL—DIMENSIONS

Capacity (Tons)	Product Code	Headroom C (in)	a (in)	b (in)	d (in)	e (in)	g (in)	h (in)	i (in)	j (in)	k (in)
1/2	AW005C	14.8	15.4	7.7	7.2	6.7	1.1	5.1	2.6	1.0	8.7
1	AW010C2	17.5	15.4	7.7	7.2	6.7	1.1	5.1	2.6	1.0	8.7



Harrington Hoists, Inc.
401 West End Avenue, Manheim, PA 17545
717-665-2000 / 800-233-3010 / Fax: 717-665-2861
www.harringtonhoists.com

Harrington Hoists, Inc.—Western Division
2341 Pomona Road, No. 103
Corona, CA 92880-6973
951-279-7100 / 800-317-7111 / Fax: 951-279-7500

Specifications and dimensions are subject to change without notice.
Rev 0 Copyright ©2015 1-15
Item No. SS-AW