

CL Challenger Lifts



Model#: CLM16-4

Mobile Column Lifting System
16,000 lb. per column lifting capacity



Model#: CLM16-4B

Wireless / Battery Powered
Mobile Column Lifting System
16,000 lb. per column lifting capacity



CLM & CLMBseries

Mobile Column Lifting System

Our Heavy-Duty mobile lifting system (4 or 6 columns) along with extra sets of accessory stands serves multiple bays with one lift system. Lightweight mobile columns can be operated on almost any solid surface, in-doors, outside or even wirelessly where electrical is not available (CLMBseries only).

Challenger mobile lifts provide the flexibility and convenience to lift any rubber tired vehicle, from small passenger cars (with special adapters) to the largest two, three or four axle vehicles up to 144,000 pounds, without pits, hydraulics or compressed air. Our Heavy-Duty mobile lifts are also capable of lifting vehicles of any axle length or wheelbase.

Models available in 16,000 or 18,000 lb. capacity columns, wireless battery operated or cabled electric powered units.

Features & Benefits:



- 1 Provides Heavy-Duty lifting for large trucks, transit and municipality vehicles
- 2 Provides lifting where 3-phase power is unavailable or cost prohibitive. Single charge all day power - up to 45 cycles at 50% capacity or up to 25 cycles at 100% capacity
- 3 For low friction and high efficiency, stability and reliability
- 4 Allows stable and safe lifting
- 5 Offers convenience and provides greater shop productivity
- 6 Provides safety and automatically shuts off when it senses objects like tools or stands in the way
- 7 Allows lifts to be operated without electrical power or communication cables
- 8 Makes columns easy to maneuver

For more information, contact your Authorized Challenger Lifts Distributor:

Model Number	Electric				Wireless / Battery	
	CLM16-4	CLM16-6	CLM18-4	CLM18-6	CLM16-4B*	CLM18-4B*
Lifting Capacity	64,000 lb. (29030kg)	96,000 lb. (43545kg)	72,000 lb. (32659kg)	108,000 lb. (48988kg)	64,000 lb. (29030kg)	72,000 lb. (32659kg)
A Height	97.6" (2350mm)					
B Max Lifting Height	69" (1752mm)					
C Length Lifting Fork	12.2" (270mm)			12.2"(270mm) or 20"(508mm)		
D Length	42.9" (1090mm)			54.5" (1384mm)		
E Width Lifting Fork	23.5" (600mm)			23.5"(600mm) or 27.5"(699mm)		
Total Width	45.3" (1150mm)					
Turning Circle	43.3" (1100mm)					
Tire Sizes	12R-24.00 to 10.00-20.00					
Min Tire w/ Reduction Sleeves	20.25"					
Lifting Speed	105 seconds			113 seconds / 117 seconds		
Full Cycles at 100% Capacity	N/A			25 strokes (up & down)		
Full Cycles at 50% Capacity	N/A			45 strokes (up & down)		
Complete Charging Cycle	N/A			8 hours		
Motor	2.4HP, 3 Phase, 60Hz			2.5 HP		
Voltage	208/230v or 440/480v			120v, 15 Amps		

* CLMBseries Wireless/Battery Operated Mobile Columns also available in 6 and 8 column configurations in both 16,000 lb. and 18,000 lb. per column capacity.



Electronic self diagnostics and automatic synchronization and communication between columns

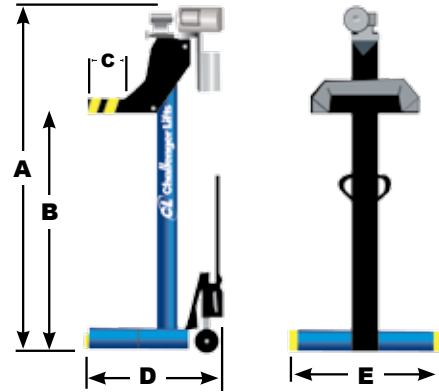

Optional Accessories:

Cable Remote Control for CLM16 and CLM18series cabled units



Light Vehicle Adapter*

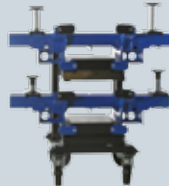

*shown with optional accessories and cart

Small Wheel Adapters



Fine adjustment screw for support stand



Support Stands



Many other customization options available.



The Automotive Lift Institute (ALI) certifies that the CLM16series, CLM18series, and CLMBseries described herein comply with the applicable provisions of the American National Standards ANSI/ALI ALCTV 2006 and are Third Party Validated by the ETL Testing Laboratory.

Challenger Lifts, Inc.
200 Cabel Street
Louisville, Kentucky 40206

Phone Toll-Free: 800-648-5438
502-625-0700
Fax: 502-625-0711

E-mail: sales@challengerylifts.com

Challenger Lifts, Inc. reserves the right to make changes to specifications without notice and without making changes retroactive. Unloading, installation and oil not included.